

Product Specification

Minimum Pressure	0.5 bar
Maximum Pressure	3.0 bar
Cold Supply Temperature	4 - 20 c
Hot Supply Temperature	55 - 65 c
1/2" male outlets	
3/4" female inlets	
38c Temperature stop position	
Minimum 10c difference between hot supply and mixed outlet temperature	
Maximum mixed temperature is recommended no higher than 43c	
Pressures should be balanced	

Cleaning

All surfaces should be cleaned using a clean damp cloth.
No abrasive cleaning agents or materials should be used.

Telephone
0844 484 7678

EcoStyle

Dual Concealed Thermostatic Shower



Please retain this manual after installation for future reference and maintenance.

Product must be installed in compliance with relevant Water Regulations and Byelaws



IMPORTANT

Flush system prior to installation
Check for leaks after installation
Hot supply must be on the left.
Check for pipes and wires, before commencing installation

Dimensions

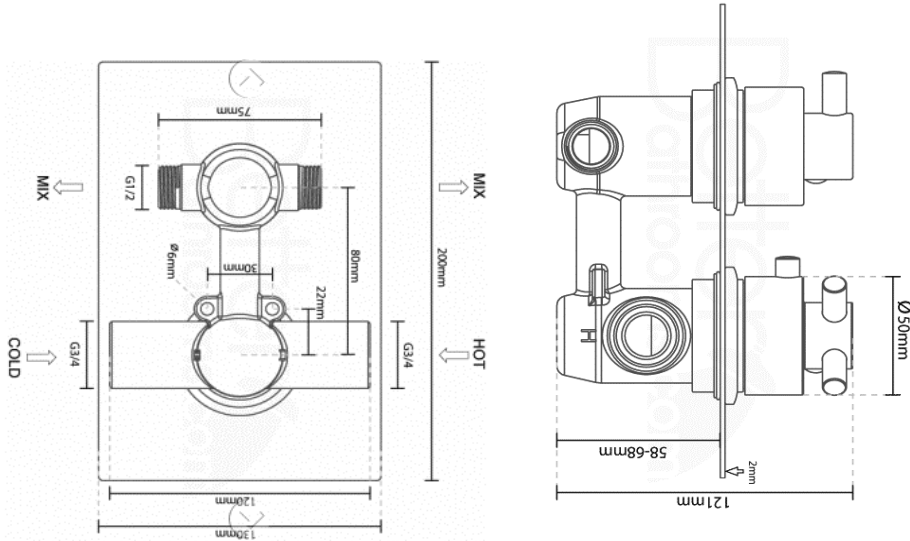

Operation

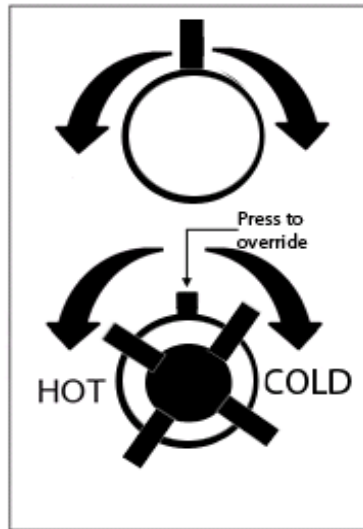

Installation

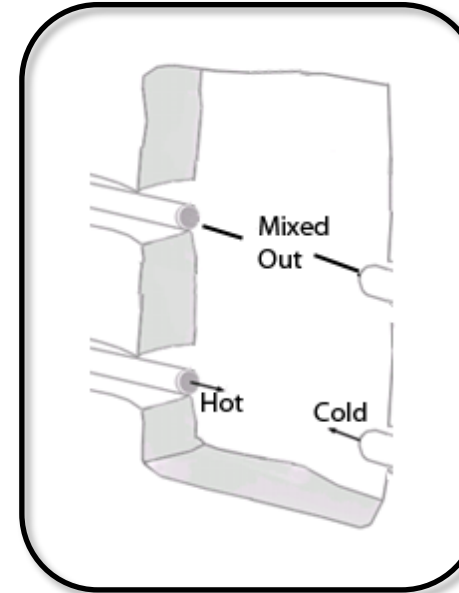

Prepare pipes in wall to connect to shower, with cold on the right.

Ensure these pipes are flushed before connecting the mixer.

Two 3/4" male fittings will be required (not supplied) to connect the water supplies to the mixer.

Two 1/2" female fittings will be required (not supplied) to connect the mixed water to the outlet fittings

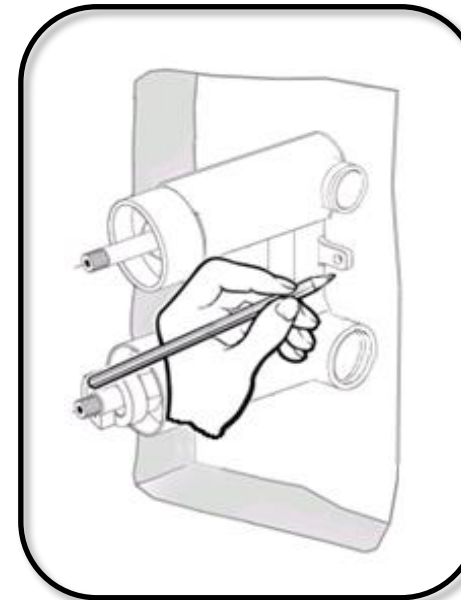

Offer the mixer into the recess and mark fixing locations.

Remove the mixer, depending on the wall type, drill the holes and insert plugs, if a solid wall.

Screw to a wooden batten if fitting into a stud wall.

Connect pipes to mixer using a suitable sealing method and then tighten.

Ensure the mixer is level.

Turn on water supply and check leaks before fitting plate

Installation

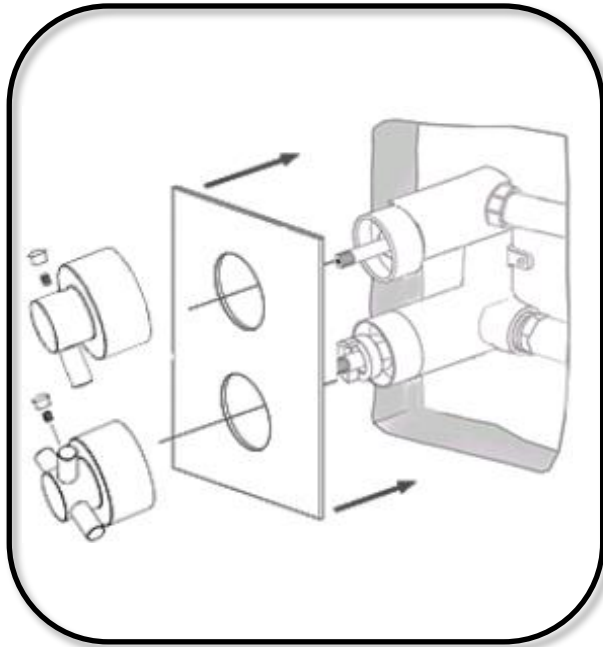

Once the mixer has been fitted and secured, push the concealing plate over the mixer body, sealant should be applied between the plate and the wall.

Next push on the flow control handle on to the top valve in the mixer, tighten the grub screw using an allen key and insert screw cover.

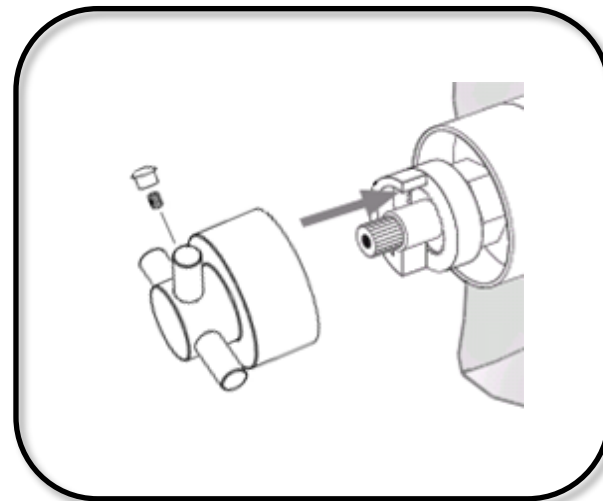

Fit temperature control handle to thermostat, ensuring the stop pin inside the handle, is located against the top of the stop ring.

To test this, once fitted, turn the handle to cold, then back to the stop position, press the button and continue to turn.

If the handle does no function correctly remove and re-assemble.

Re-calibration

Your product is factory set under balanced pressures, with specific inlet temperatures, as your site conditions may differ, the temperature stop position may require re-setting, to achieve the 38c.

Turn the handle to the stop position, remove screw cover and loosen grub screw, inside handle.

Pull the handle from the mixer. DO NOT remove the plastic stop ring.

Turn the spindle until the 38c is achieved, once this has been reached, replace the handle, so that the stop pin inside sits against the stop ring.

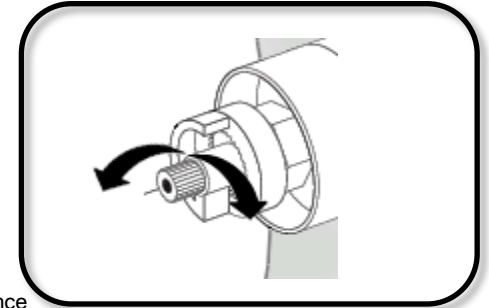

Thermostat removal (Turn off water supply)

Over a period of time, lime scale or debris build up may occur and could affect the performance of the thermostat.

Cleaning of the thermostat could assist in returning the thermostat to its original performance.

Remove the handle from the mixer, remove the stop ring and unscrew the chrome shroud.

Using a spanner remove the thermostatic cartridge.

Run this under warm water and rub or wipe to remove build up.

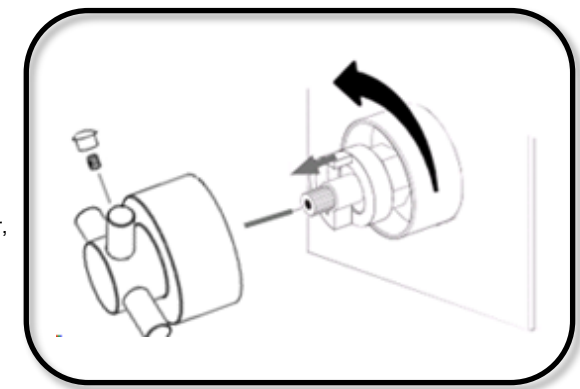

Maintenance

Flow control / diverter valve removal

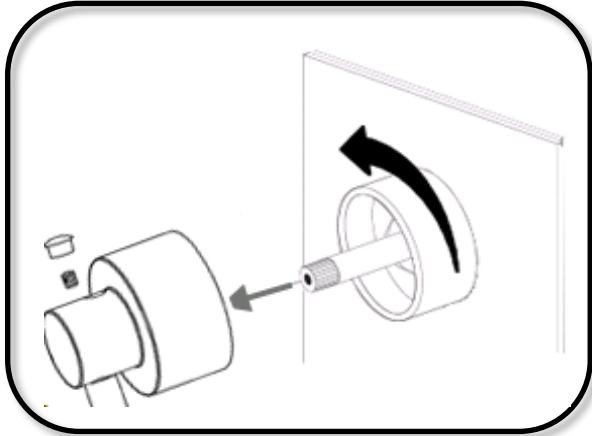

In the event that you should need to remove the flow control valve, first turn off water supply.

Remove the handle, unscrew the chrome shroud.

Using a spanner remove the flow control valve.

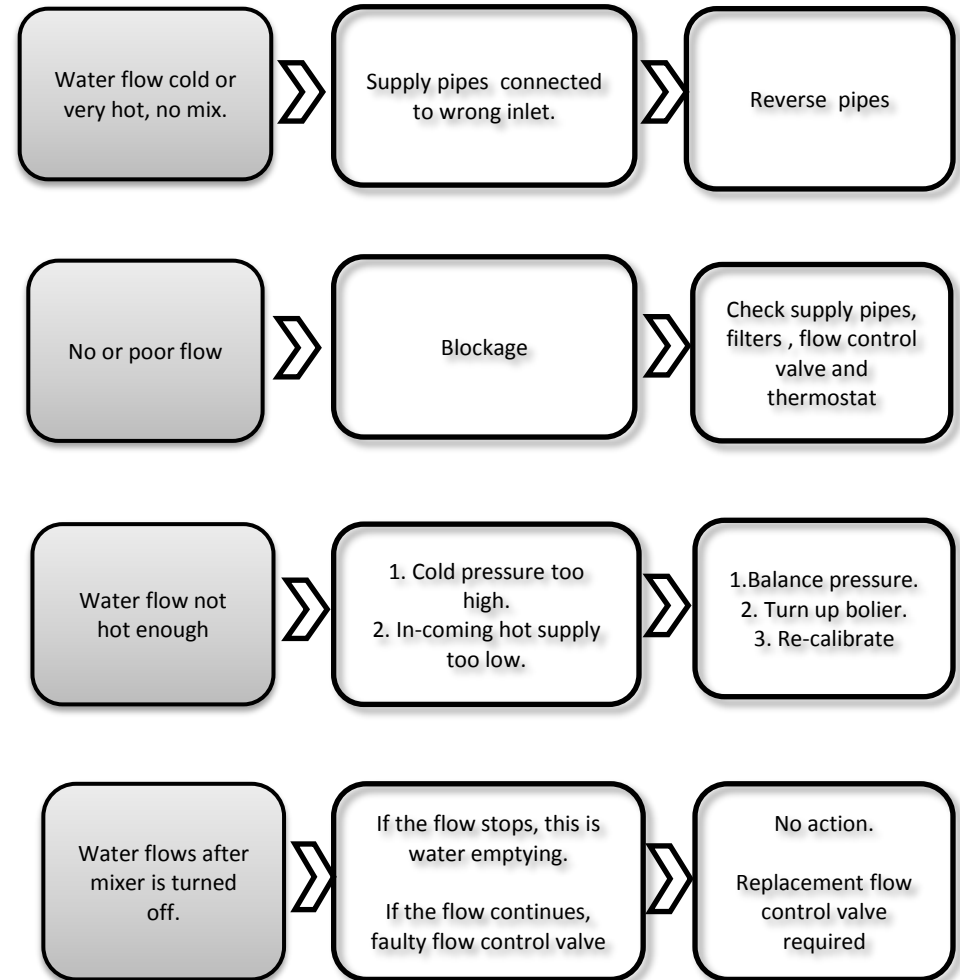

Guarantee

Your product comes with a 1 year guarantee when installed, used and cleaned in accordance with this manual.

Not covered by the guarantee is:

- Breakdown due to -
 - a) Use other than domestic
 - b) Wilful act of neglect
 - c) Any malfunction resulting from incorrect use
 - d) Incorrect setting of controls
 - e) Any malfunction resulting from poor water quality
- Repair costs for damage caused by foreign objects or substances
- Total loss of the product due to non-availability of parts
- Compensation for loss of use of the product or consequential loss of any kind.
- Call out charges where no fault has been found with the product.

Your product comes with a 1 year guarantee when installed, used and cleaned in accordance with this manual.

Not covered by the guarantee is:

- The cost of repair or replacement of pressure relief devices, spray heads, hoses, riser rails and/or wall bracket or any other accessories installed at the same time.
- The cost of routine maintenance, adjustments, overhaul, modifications, loss or damage, arising therefrom, including the cost of repairing damage, breakdown, malfunction caused by corrosion, furring, pipe scaling, lime scale, system debris or frost.