

## OPERATION

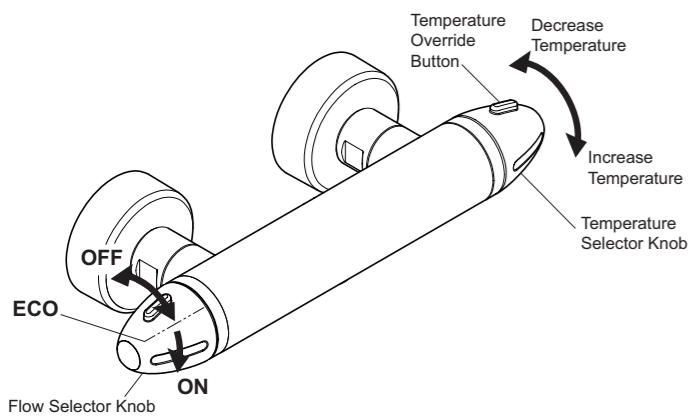

### Adjusting the Temperature

The temperature is controlled by rotating the temperature selector knob. For safety reasons, the temperature is limited by an override stop. To obtain a higher temperature, press the override button on the temperature selector knob and continue to rotate the knob.

### Adjusting the Flow

The flow is controlled by rotating the flow selector knob. The **ECO** mode provides an economic flow rate to save water, to get **FULL FLOW** push the button in and continue to rotate.

## CLEANING

### Cleaning

Many household cleaners contain abrasives and chemical substances, and should not be used for cleaning plated or plastic fittings. These finishes should be cleaned with a mild washing up detergent or soap solution, and then wiped dry using a soft cloth.

**Important! The showerhead must be descaled regularly**, keeping the showerhead clean and free from limescale will ensure that your shower and showerhead continue to perform to their maximum. A blocked showerhead can restrict the flow rate and may cause damage to your shower.

## FAULT DIAGNOSIS

If you require a Mira trained service engineer or agent, refer to section: 'Customer Services'.

Symptom	Cause/Rectification
Water too hot or too cold	Inlets reversed (hot supply to cold supply). Rework inlet pipework. Check filters for any blockage. Check the maximum temperature setting (If you have a combination type boiler it may not be producing sufficient hot water at the desired flow rate). Fit a flow regulator to the shower valve outlet. Installation conditions outside operating parameters. Refer to Specifications and Commissioning
Poor temperature control	Make sure that the inlet temperature differentials are sufficient. Refer to Specifications.
Fluctuating or reduced flow	Check the shower handset, hose and filters for any blockage. Set at Eco position. Press the override button and rotate the knob. Make sure that the maintained inlet pressures are nominally balanced and sufficient. Refer to Specifications. Air lock or partial blockage in the pipework.
Water leaking from the shower handset	Normal for a short period after shut off. Check that the pressures are not in excess of the specifications for this product.

## SPARE PARTS

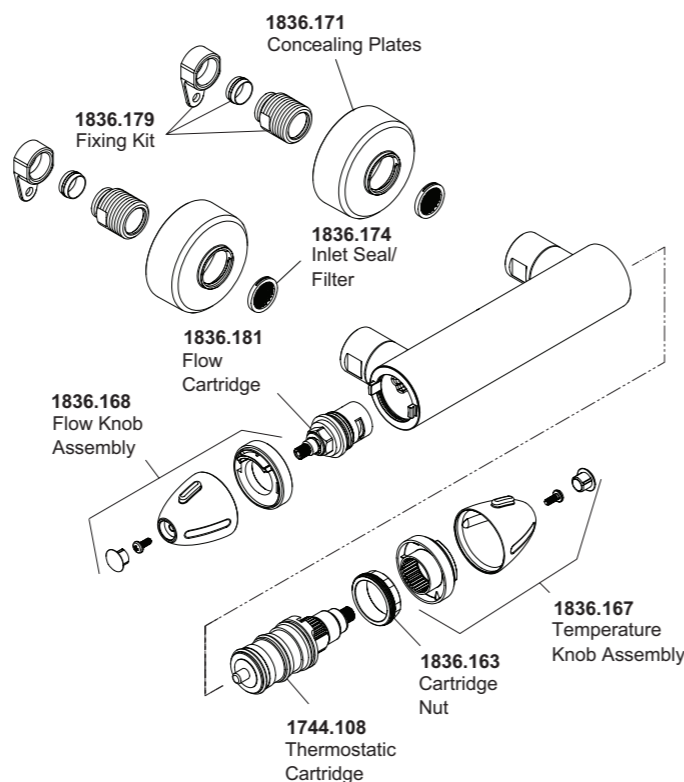

## CUSTOMER SERVICE

### Guarantee

Your product has the benefit of our manufacture's guarantee which starts from date of purchase. This guarantee only applies in the United Kingdom and Republic of Ireland. To activate this guarantee, please return your completed registration card, visit our website or free phone 0800 5978551 within 30 days of purchase (UK only). Within the guarantee period we will resolve defects in materials or workmanship, free of charge, by repairing or replacing parts or product as we may choose.

- This guarantee is in addition to your statutory rights and is subject to the following conditions:
  - The guarantee applies solely to the original installation under normal use and to the original purchaser only. The product must be installed and maintained in accordance with the instructions given in this guide
  - Service must only be undertaken by us or our appointed representative.
- Note!** If a service visit is required the product must be fully installed and connected to services.
- Repair under this guarantee does not extend the original expiry date. The guarantee on any replacement parts or product ends at the original expiry date.
  - For shower fittings or consumable items we reserve the right to supply replacement parts only.

### The guarantee does not cover:

- Call out charges for non product faults (such as damage or performance issues arising from incorrect installation, improper use, inappropriate cleaning, lack of maintenance, build up of limescale, frost damage, chemical attack, corrosion, system debris or blocked filters) or where no fault has been found with the product.
- Water or electrical supply, waste and isolation issues.
- Compensation for loss of use of the product or consequential or indirect loss of any kind.
- Damage or defects caused if the product is repaired or modified by persons not authorised by us or our appointed representative.
- Routine maintenance or replacement parts to comply with the requirements of the TMV2 or TMV3 healthcare schemes
- Accidental or wilful damage.
- Products purchased ex-showroom display.

### What to do if something goes wrong

If your product does not work correctly refer to this manual for fault diagnosis and check that it is installed and commissioned in accordance with our instructions. If this does not resolve the issue, contact us for help and advice.

### Helpdesk Service

Contact our Customer Services Team for product advice, to purchase spare parts or accessories or to set up service visit. You can contact us via phone or e-mail - contact details below.

Please provide your model name, power rating (if applicable) and date of purchase.

### Mira Showers Website (www.mirashowers.co.uk)

Visit our website to register your guarantee, download user guides, diagnose faults, purchase our full range of accessories and popular spares, or request a service visit.

### Spares and Accessories

We hold the largest stocks of genuine Mira spares and accessories. Contact us for a price or visit our website to purchase items from our accessory range and popular spares. (Only available in the United Kingdom)

### Service / Repairs

No one knows our products better than our nationwide team of Service Technicians. We can carry out service or repair work to your product both during and after the guarantee period. (Only available in the United Kingdom and Republic of Ireland) Ask about our fixed price service repairs.

### To Contact Us: UK

**0844 571 5000**  
Calls cost 7p per minute plus your phone company's access charge

Fax: 01 242 282595

E-mail: Visit [www.mirashowers.co.uk/contactus](http://www.mirashowers.co.uk/contactus)

Mira Customer Services  
Cromwell Road, Cheltenham,  
Gloucestershire, GL52 5EP

### To Contact Us: Eire Only

**01 531 9337**

E-mail: [CustomerServiceEire@mirashowers.com](mailto:CustomerServiceEire@mirashowers.com)

Mira is a registered trade mark of Kohler Mira Limited.  
The company reserves the right to alter product specifications without notice.



## Mira Coda Pro Thermostatic Bar Valve

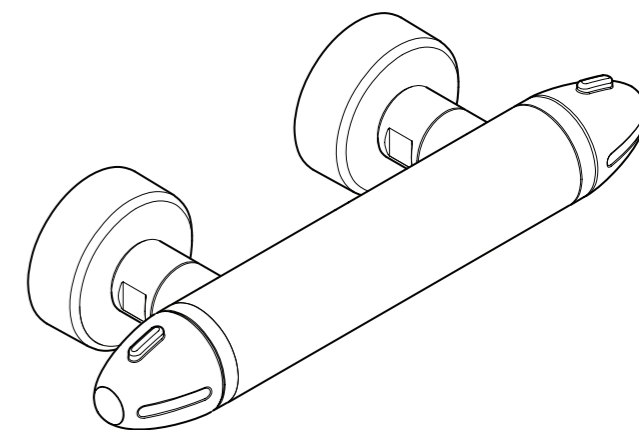

These instructions must be left with the user

## INTRODUCTION

Thank you for purchasing a quality Mira product. To enjoy the full potential of your new product, please take time to read this guide thoroughly, having done so, keep it handy for future reference.

### Guarantee

For **domestic installations**, Mira Showers guarantee the Mira Coda against any defect in materials or workmanship for a period of **five** years from the date of purchase (shower fittings for one year).

For **non-domestic installations**, Mira Showers guarantee the Mira Coda against any defect in materials or workmanship for a period of **one** year from the date of purchase.

For terms and conditions refer to the back cover of this guide.

**Design Registration:** GB 0013711355-0006, 0013711355-0007, 0013711355-0010

**Patents:** GB 2 407 138

Recommended Usage	
Domestic	✓
Light Commercial	✓
Heavy Commercial	✗
Healthcare	✗

## SAFETY : WARNINGS

**WARNING - This product can deliver scalding temperatures if not operated, installed or maintained in accordance with the instructions, warnings and cautions contained in this guide.**

The function of a thermostatic mixing valve is to deliver water consistently at a safe temperature. In keeping with every other mechanism, it cannot be considered as functionally infallible and as such, cannot totally replace a supervisor's vigilance where that is necessary. Provided it is installed, commissioned, operated and maintained within manufacturers recommendations, the risk of failure, if not eliminated, is reduced to the minimum achievable.

### Caution!

1. Read all of these instructions and retain this guide for later use.
2. Installation must be carried out in accordance with these instructions, and must be conducted by designated, qualified and competent personnel.
3. Pass on this guide in the event of change of ownership of the installation site.
4. Follow all warnings, cautions and instructions contained in this guide.
5. Make sure that you fully understand how to operate this shower before use, read all operating instructions and retain this guide for future reference.
6. This product is not intended for use by persons (including children) with reduced physical, sensory or mental capabilities, or lack of experience and knowledge, unless they have been given supervision or instruction concerning the use of the product by a person responsible for their safety.
7. Children should be supervised to ensure that they do not play with the product.
8. **DO NOT** perform any unspecified modifications to the shower or its accessories. When servicing only use genuine Kohler Mira replacement parts.
9. **DO NOT** fit any form of outlet flow control. Only Mira recommended outlet fittings should be used.
10. **DO NOT** operate the temperature control rapidly, allow 10 – 15 seconds for the temperature to stabilise before use.
11. Care is required when adjusting flow or temperature, make sure that the temperature has stabilised.
12. Care is required if the product is turned off and back on during showering as this may result in unstable temperature. Ensure temperature has stabilised before re-using product.
13. Sunburn or skin conditions can increase your sensitivity to hot water. Make sure that you set the shower to a cooler temperature.
14. The water supplies to this product must be isolated if the product is not to be used for a long period of time. If the product or pipework is at risk of freezing during this period they should also be drained of water.
15. When this product has reached the end of its serviceable life, it should be disposed of in a safe manner, in accordance with current local authority recycling, or waste disposal policy.

## SPECIFICATIONS

### Pressures

- Max Static Pressure: **10 Bar**.
- Max Maintained Pressure: **5 Bar**.
- Min Maintained Pressure: (Gas Water Heater): **1.0 Bar** (for optimum performance supplies should be nominally equal).
- Min Maintained Pressure (Gravity System): **0.1 Bar** (0.1 bar = 1 Metre head from cold tank base to shower handset outlet).

### Thermostatic Shut-down

- For safety and comfort the thermostat will shut off the mixing valve **within 2 Seconds** if either supply fails (achieved only if the blend temperature has a minimum differential of 12°C from either supply temperature).

### Connections

- **Hot: Left** - 15 mm Compression to pipework, 3/4" BSP to valve.
- **Cold: Right** - 15 mm Compression to pipework, 3/4" BSP to valve.
- **Outlet: Bottom**, 1/2" BSP Male to flexible hose.

**Note!** This product does not allow for reversed inlets and will deliver unstable temperatures if fitted incorrectly.

### Temperatures

- Close temperature control is provided between **20°C and 50°C**.
- Optimum Thermostatic Control Range: **35°C to 45°C** (achieved with supplies of 15°C cold, 65°C hot and nominally equal pressures).
- Recommended Hot Supply: **60°C to 65°C (Note!** The mixing valve can operate at temperatures up to 85°C for short periods without damage. However for safety reasons it is recommended that the maximum hot water temperature is limited to 65°C).
- Minimum Recommended Differential between Hot Supply and Outlet Temperature: **12°C at desired flow rates**.
- Minimum hot water supply temperature: **55°C**.

## INSTALLATION

### Suitable Plumbing Systems

#### Gravity Fed:

The thermostatic mixer must be fed from a cold water cistern (usually fitted in the loft space) and a hot water cylinder (usually fitted in the airing cupboard) providing nominally equal pressures.

#### Gas Heated System:

The thermostatic mixer can be installed with a combination boiler.

#### Unvented Mains Pressure System:

The thermostatic mixer can be installed with an unvented, stored hot water system.

#### Mains Pressurised Instantaneous Hot Water System:

The thermostatic mixer can be installed with systems of this type with balanced pressures.

#### Pumped System:

The thermostatic mixer can be installed with an inlet pump (twin impeller). The pump must be installed on the floor next to the hot water cylinder.

### General

Installation must be carried out in accordance with these instructions, and must be conducted by designated, qualified and competent personnel. The installation must comply with the "Water Supply Regulations 1999 (Water Fittings)" or any particular regulations and practices, specified by the local water company or water undertakers.

**Note!** Make sure that all site requirements correspond to the information given in section: '**Specifications**'.

1. The product must not be installed in an area where it may freeze. Pipework to the product that could become frozen must be properly insulated.
2. Do not install the product in a position in which service access is restricted.
3. For stud partitions alternative fixings may be required.
4. Isolating valves must be installed close to the product for ease of maintenance.
5. Pipework must be rigidly supported and avoid any strain on the connections.
6. Pipework dead-legs should be kept to a minimum.
7. If pipework enters the product from the rear through a hole in the wall, provision must be made to prevent water ingress back into the wall structure.
8. The showerhead should be positioned so that it discharges down the centre line of the bath or across the opening of a shower cubicle.
9. Only use the inlet connections supplied with the product. **DO NOT** use any other type of fittings.
10. All pipework must be checked for leaks before the product installation is completed. The product should be pressurised & the inlet & outlet connections inspected.
11. **DO NOT** overtighten connections, screws or grubscrews as product damage may occur.
12. Upon completion of installation, or if the product is dismantled during installation or servicing, then the product must be inspected to ensure that there are no leaks.
13. Having completed the installation, make sure that the user is familiar with the operation of the product.

14. The position of the shower and shower fittings must provide a minimum gap of 25 mm between the showerhead and the spill over level of any bath, shower tray or basin and a minimum gap of 30 mm between the showerhead and the spill over level of any toilet, bidet or other appliance with a Fluid Category 5 backflow risk (see diagram).

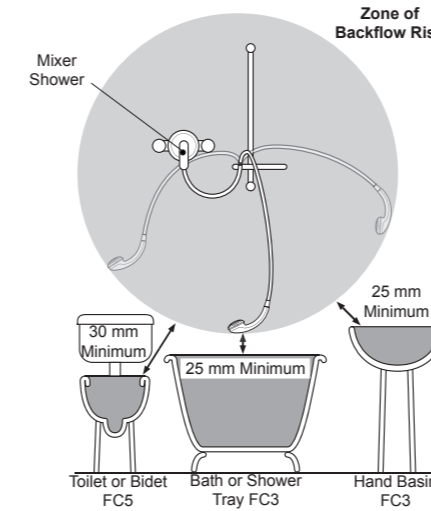

**Note!** There will be occasions when the hose retaining ring will not provide a suitable solution for Fluid Category 3 installations, in these instances an outlet double checkvalve must be fitted, this will increase the required supply pressure typically by 10kPa (0.1 bar). Double checkvalves fitted in the inlet supply to the appliance cause a pressure build up, which affect the maximum static inlet pressure for the appliance and must not be fitted. For Fluid category 5 double checkvalves are not suitable.

### Installation of the Bar Valve

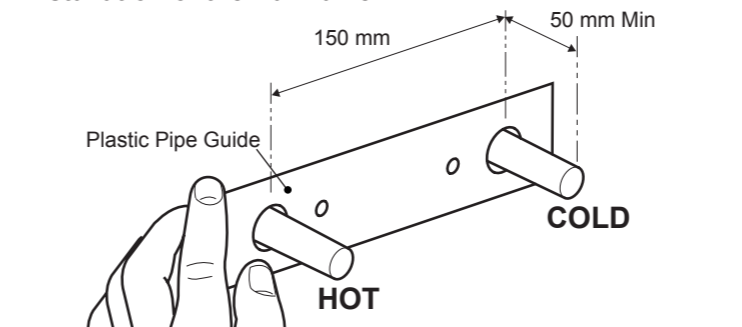

1. Fit the plastic pipe guide over the inlet pipes. Level the pipe guide and secure to the wall to hold in position. **Leave the guide in place and finish the wall.**

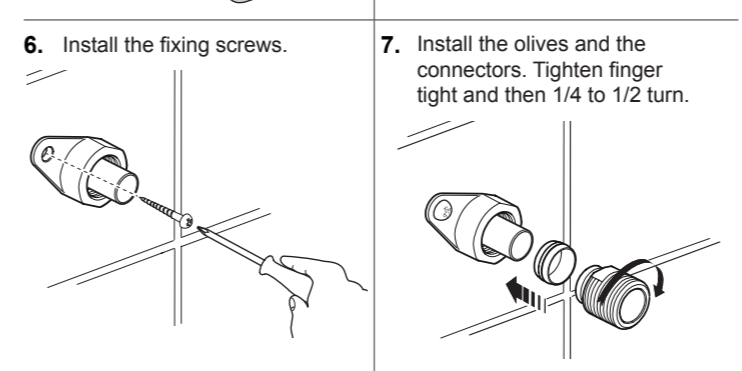
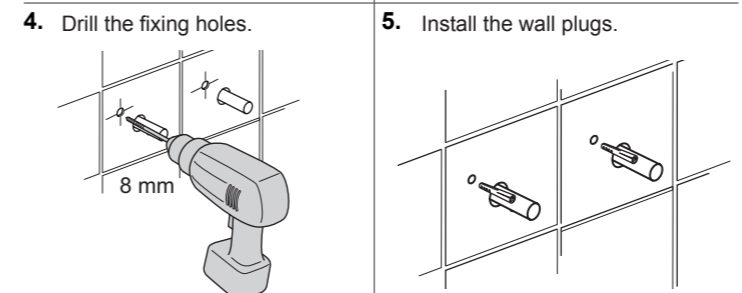
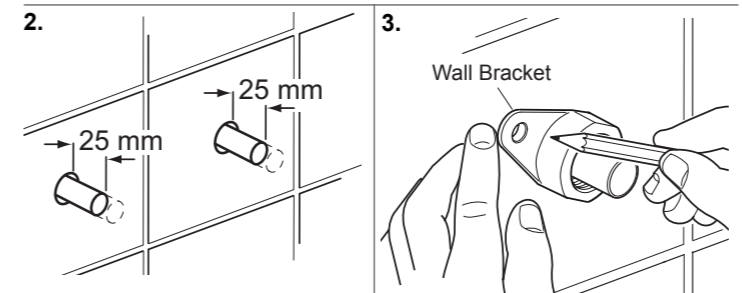

8. Turn on the water supply and flush the pipework.
9. Install the concealing plates.

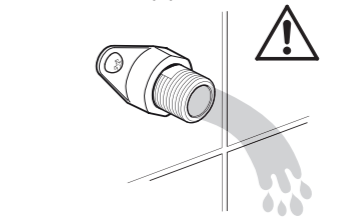

10. Assemble the bar valve with a sealing washer/filter in each inlet and attach to the wall bracket. **Note!** Connections are: **Hot-Left, Cold-Right**.

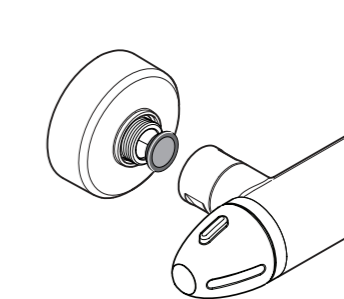

11. Install the shower fittings (not supplied) and check for leaks.

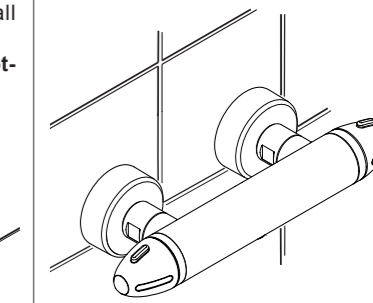

**Note!** This bar valve is designed to connect to a Mira hose with a conical nut. If a non-Mira hose is to be used with this product, an additional washer may be required (supplied) to achieve a satisfactory seal between the valve outlet and the hose connector.

## COMMISSIONING

### Maximum Temperature Setting

Before using the shower, the maximum temperature must be checked to make sure that it is at a safe level. It has been preset to a safe showering temperature under ideal conditions at the factory, appropriate for most systems. However, site conditions and personal preference may make it necessary to reset this temperature.

**Note!** Make sure that the hot water temperature is at least 55°C and that there is sufficient supply.

**Caution!** Before testing the mixer, make sure that the hot and cold water is flowing correctly by exercising the temperature selector knob between the cold and hot stops.

1. Turn the temperature selector knob **anticlockwise** until it stops and test that the temperature of the water from the shower outlet is hot enough.
2. If not, depress the override button and **carefully** rotate the knob further. If the water temperature is still not hot enough complete the following procedure.
3. Rotate the temperature selector knob back to the override position.
4. Remove the concealing cap and the fixing screw.
5. Pull off the temperature selector knob without disturbing the stop assembly.
6. Replace the temperature selector knob so that the button is at the **1 O'clock position**.
7. Rotate the temperature selector knob against the stop, wait for the water to stabilise and test that the temperature of the water from the shower outlet is hot enough. If the water temperature is still not hot enough repeat the procedure until a maximum safe temperature is achieved at the override position.
8. Refit and tighten the fixing screw, refit the concealing cap.

