

## Product Specification

~ Minimum Working Pressure	0.5 bar
~ Maximum Working Pressure	4.0 bar
~ Cold Water Supply Temp	4 - 20 c
~ Hot Water Supply Temp	55 - 85 c
~ Fixing Centres	150mm +/- 20mm
~ Outlet size	1/2" Bottom Outlet 3/4" Top Outlet
~ Valve type	Dual Bar Shower Valve
~ Temperature stop	38c Temperature Stop with Override
~ Mixer Inlets	3/4" Inlets

Always maintain a minimum 10c difference between hot inlet temp and mixed water  
 Hot supply must be connected to left inlet, indicated by red dot on mixer body.  
 Pressures should be balanced for optimum performance

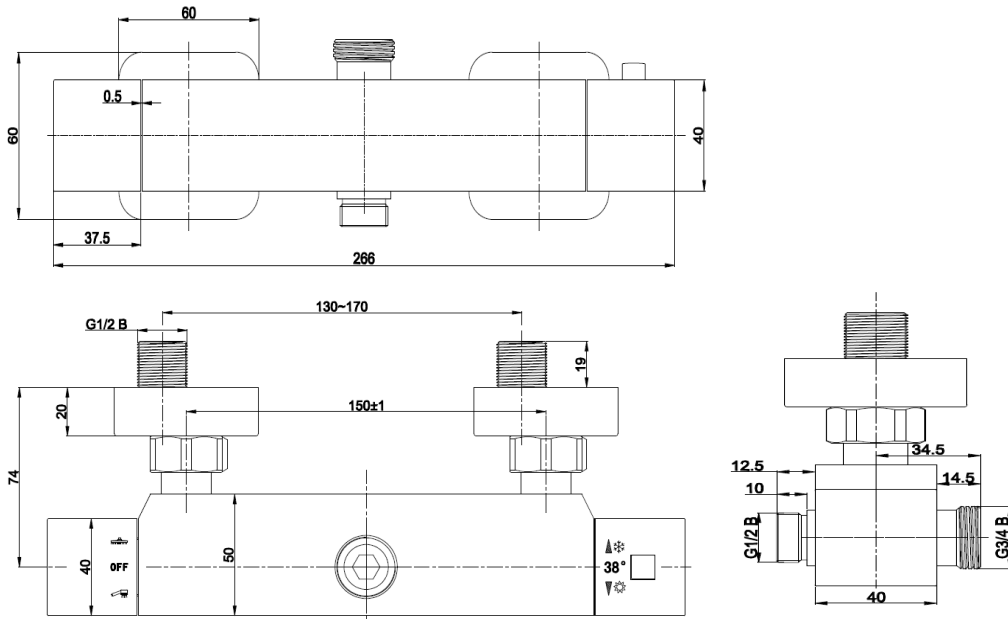

## Square Dual Bar Shower Valve



Please retain this manual after installation for future reference and maintenance.

**Product must be installed in compliance with relevant Water Regulations and Byelaws**

Telephone  
**0333 777 4777**

**Installation** (design of trims may differ depending on product)

Pipe work should be prepared and **MUST** be flushed to remove debris.

Prior to installation ensure water supply is turned OFF

Ensure hot supply is connected to inlet indicated with red dot this will be on the left of the mixer.

The pipes should be secured and a suitable fixing method used to support the mixer

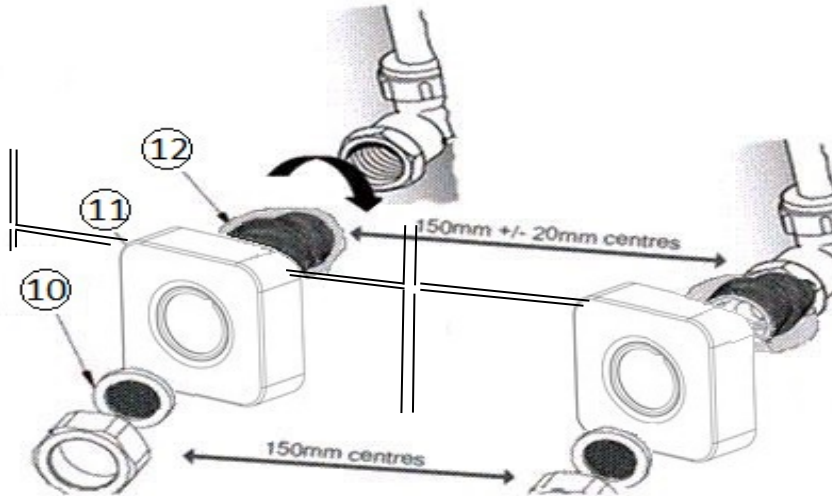

- > Using an adequate form of seal, connect the 1/2" section of the offset connector (12) to the pipe fitting not supplied, ensuring that the 3/4" section aligns with the mixer inlets.
- > Once positioned, connect the trim plate (11) onto the 3/4" section of the offset connector (12) and screw this up to the finished wall surface.
- > Fit the seals (10) into the mixer nuts .
- > Connect mixer nuts to connectors (12) and tighten, to create a watertight seal.
- > Once installed turn on water and check for leaks.

**Cleaning**

The product should be cleaned using a soft damp cloth, no abrasive agents or materials must be used, or this will invalidate your guarantee.

Over a period of time, lime scale may build up on the thermostat, this will need to be cleaned, as this will affect the temperature function.

Follow the Cartridge Removal instruction and rinse under warm water, rubbing or brushing to clear any lime scale/debris.

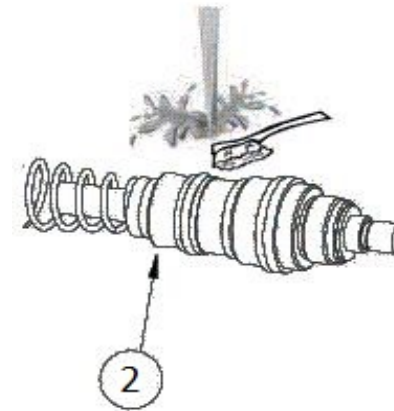

**Box Contents**

Mixer	1
Off-set connectors	2
Trim plates	2
Seal washers	2

**Maintenance**  
**ON/OFF Valve Removal**

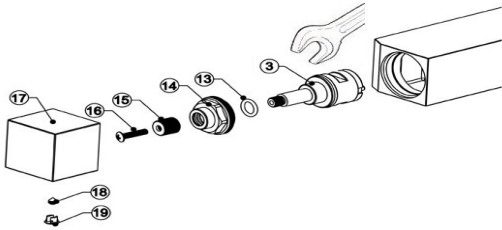

- Removal of the mixer from the wall is recommended, turn off water.
- Remove chrome cap (19) in end of handle (17) , using a sharp knife.
- Remove screw (18) inside handle (17).
- Pull handle (17) from mixer
- Unscrew valve (3) from mixer, using a spanner
- Remove screw (16) inside valve (3)
- Unscrew handle wheel set (4) from valve (3) , using a spanner
- Pull gear cover (14) and O ring (13) from valve (3)

**Filter Cleaning**

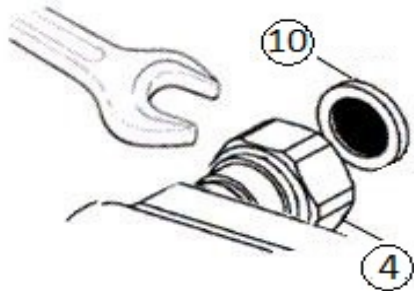

- Removal of the mixer from the wall is required, turn off water.
- Spanner the mixer nuts on the valve to release the mixer from the supply connections.
- Once the mixer has been removed, take out the filters (10) from the mixer nuts and run under warm water to clean.
- Replace filters and replace mixer, tighten mixer nuts.

**Operation**

- To increase the temperature of the mixed water turn the handle on the right, towards the user.
- When the temperature stop is reached, to increase the temperature further, press the button and continue to turn.

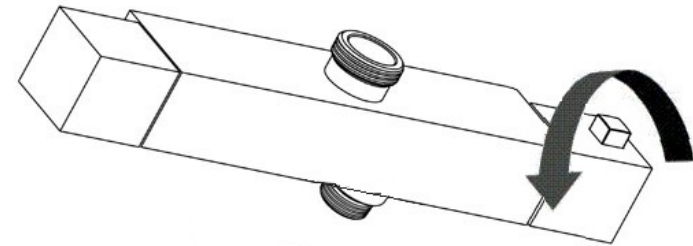

- To control the flow of water and to turn on and off, turn the handle on the left, away from the user to increase flow.

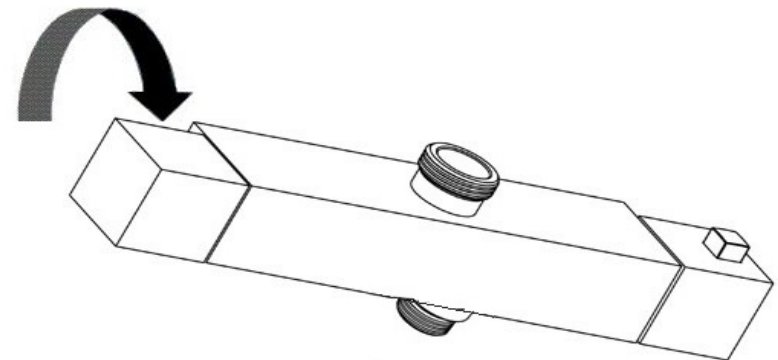

### Calibration

This product is factory set to 38c (stop position), this is under factory conditions, on receipt depending on system, the product may require calibration

To do this turn the temperature handle to the stop position and measure the water temperature using a household thermometer.

If a temperature change is required, remove the handle cap, taking care not to damage this, then remove the handle screw.

Pull the handle from the mixer and turn the thermostat spindle until the desired temperature is reached.

(Do not remove the stop ring -25)

Once the desired temperature has been reached, replace the handle, so that the stop inside the handle, sits up against the stop ring (25).

Replace the handle screw and cap.

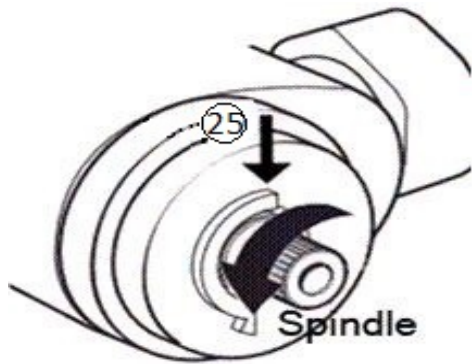

### **IMPORTANT**

**Mixed outlet temperature must always be 10c less than hot supply temperature**

### Maintenance Cartridge Removal

Removal of the mixer from the wall is recommended, turn off water  
Remove chrome cap (19) in end of handle (26) , using a sharp knife.

Remove screw (18) inside handle (26).

Pull handle (26) from mixer (1)

Remove stop ring (25)

Unscrew thermostat (2) using a spanner or grips

Then follow "Calibration (page 3) instruction to re-set

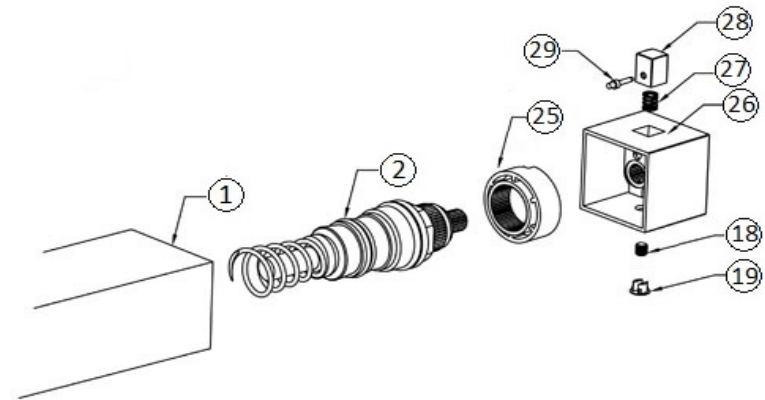

## Parts Breakdown

Part No.	Description
1	Mixer body
2	Thermostatic cartridge
3	Flow control valve
4	Body nut
5	O Ring
6	Spring
7	Non-return valve
8	Filter screen
9	Inlet
10	Filter seal
11	Wall trim plate
12	Off set connector
13	O Ring
14	Gear cover
15	Hand wheel set
16	Handle screw
17	Flow control handle
18	Handle cap
19	Handle screw
20	1/2 Bottom Outlet
21	O Ring
22	O Ring
23	O Ring
24	3/4 Top Outlet
25	Thermostat stop ring
26	Temperature control handle
27	Spring
28	Button pin
29	Button
30	Red marking
31	Bule marking

## Parts Breakdown

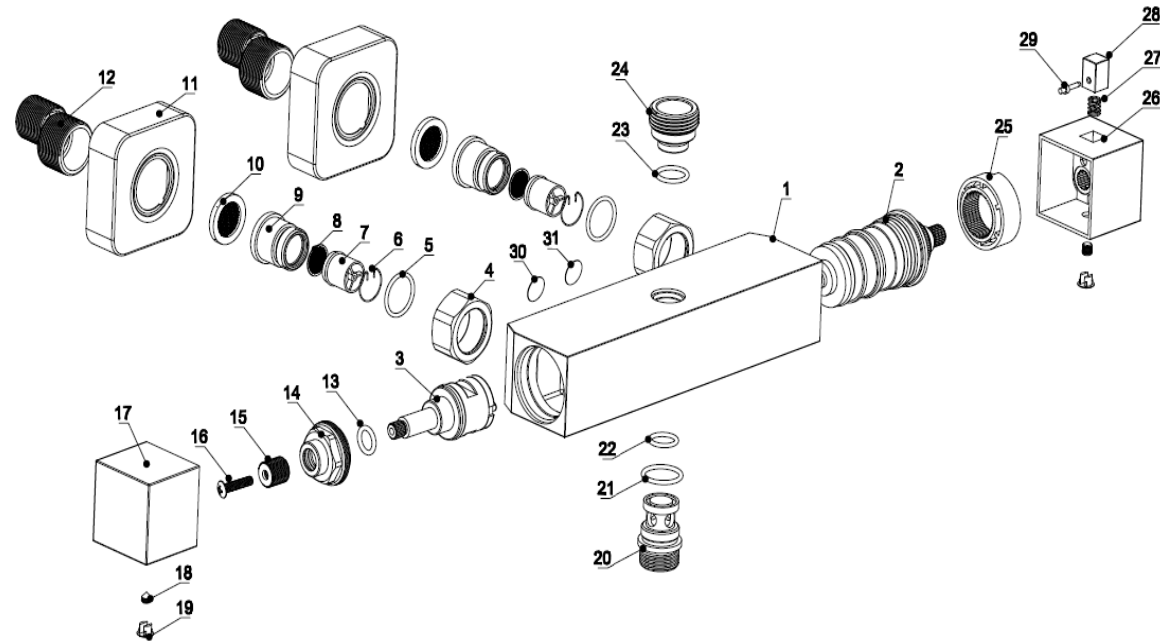

No water flow



- 1. Cold water failure, thermostatic anti-scald activated
- 2. No supply to mixer, supply pipe blockage
- 3. No supply to mixer, isolation valves closed
- 4. Blockage in filters, thermostat or flow control valve
- 5. Non-return valve stuck in closed position



- 1. No action
- 2. Remove mixer, flush pipes
- 3. Open isolation valves
- 4. Remove components and clean.
- 5. Remove mixer, press non-return valve several times

Poor water flow



- 1. Blockage in filters, thermostat or flow control valve
- 2. Isolation valves not fully open
- 3. Insufficient water pressure
- 4. Pump fitted, but not starting up
- 5. Blockage or air lock in supply pipe



- 1. Remove components and clean
- 2. Open isolation valves
- 3. Fit pump (not to mains)
- 4. Check sufficient flow (l/min) to activate pump
- 5. Remove mixer and flush pipes

Water too cold



- 1. Hot water isolation valve not fully opened
- 2. Blockage on hot supply
- 3. Blockage on hot side of mixer
- 4. Mixer has not been calibrated
- 5. Pressure difference between hot and cold
- 6. Hot water, not hot enough 55-85c



- 1. Open isolation valve
- 2. Remove mixer and flush pipes
- 3. Open mixer and check non-return valve function
- 4. Re-set temperature - see instruction
- 5. Pressures need to be balanced to allow mix of water.
- 6. Increase hot water supply via boiler or cylinder.

Temperature fluctuation



- 1. Water supply in use elsewhere in the house
- 2. Pressure/temperature fluctuation from system
- 3. Blocked thermostat



- 1. A slight fluctuation will occur, until the thermostat has adjusted itself.
  - 2. System issue with supply to mixer, consult an engineer
  - 3. Remove thermostat and clean.
- If the above do not resolve the issue contact the supplier

Dripping/ running after turning off



- 1. Has the flow control been fully closed
- 2. Does the dripping stop



- 1. Fully close the flow control valve
  - 2. If the dripping stops, this is residual water emptying.
- This can also be caused by not flushing the system before installation, which damages the flow control valve.

# Guarantee

## Not covered by the guarantee is:

- Breakdown due to -
  - a) Use other than domestic
  - b) Wilful act of neglect
  - c) Any malfunction resulting from incorrect use
  - d) Incorrect setting of controls
  - e) Any malfunction resulting from poor water quality
- Repair costs for damage caused by foreign objects or substances
- Total loss of the product due to non-availability of parts
- Compensation for loss of use of the product or consequential loss of any kind.
- Call out charges where no fault has been found with the product.

## Not covered by the guarantee is:

- The cost of repair or replacement of pressure relief devices, spray heads, hoses, riser rails and/or wall bracket or any other accessories installed at the same time.
- The cost of routine maintenance, adjustments, overhaul, modifications, loss or damage, arising therefrom, including the cost of repairing damage, breakdown, malfunction caused by corrosion, furring, pipe scaling, lime scale, system debris or frost.