

Product finish	Chrome
Product category	Monobloc
First supplied date	

EAN 13 barcode	5015834050096
Location of DOM trace code:	ABID1(mm/yy) on rear of body



Nb. Model shown may not be displayed in the finish as described.

Product features:

- Metal construction throughout
- Quarter turn handle action for precise flow control
- Modern minimalism with flair
- Supplied complete with flexible tail pipes for fast simple fitting
- Antisplash spout supplied as standard

Additional information / Parts included:

Product dimensions & valve type:

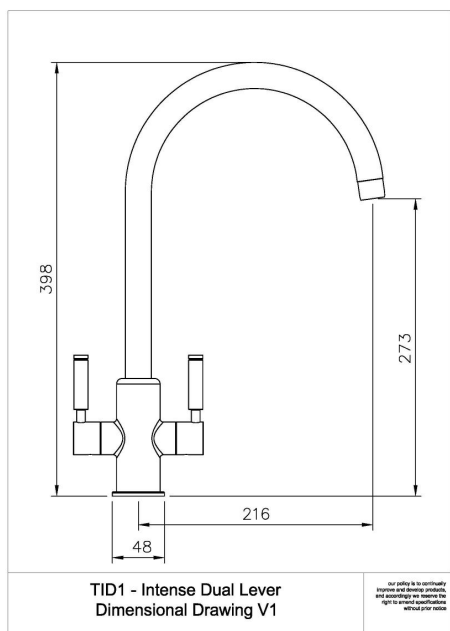

- **Overall Height / projection:** 398 mm
- **Exit reach:** 216 mm
- **Exit height:** 273 mm
- **Centre distance(s):** n/a mm
- **Base diameter(s):** 48 x n/a mm
- **Recommended fixing hole diameter:** Ø 35 mm
- **Max. surface fixing depth:** 40 mm
- **Control valve type:** Quarter turn ceramic disc
- **Valve detail:** 8-28
- **DDA compliant design?** Yes

Product flow characteristics:

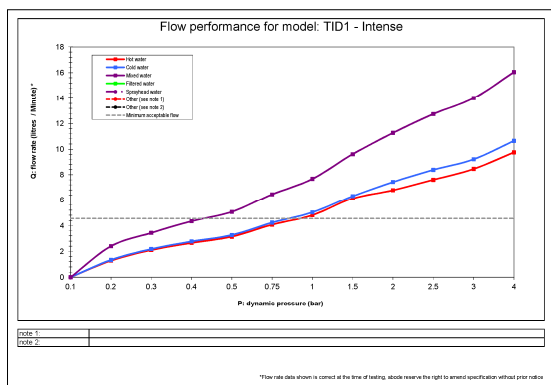

- **Min / Max water pressure:** 0.50 / 5.50 bar (MP)
- **Recommended / Maximum water temperature:** 46°C / 70°C
- **Part G:**
Unrestricted mixed flow rate, 3 bar (litres / min): 14.01

*Flow results are produced under test conditions and represent the non flow regulated dynamic output of the product model.

LP (lower pressure) less than 0.5 bar
 MP (medium pressure) 0.5 bar to 1 bar
 HP1 (high pressure) 1 bar to 2 bar
 HP2 (very high pressure) 2 bar or more

Minimum flow rate (1 GPM) based on mixed flow.

Flow regulator included? N/A

Inlet pipes:

- Tail pipe inlet / outlet size: M10 / 1/2" BSPP Male / 15mm ID
- Inlet pipe type / length: Flexible stainless braided hose / 370 mm

Spout detail & Flow characteristics:

- | | |
|---|---|
| <ul style="list-style-type: none"> • Spout diameter: 22 mm • Spout aerator size: M22x1 M • Spout rotation range: 360° • Aerator type: Honeycomb Aerator • Aerator colouring: Grey/Light blue • Spout connection: Grub screw at rear of body | <ul style="list-style-type: none"> • Product flow characteristics: Single flow • Non return valve (NRV) supplied: X 2 Integral to hot & cold flexis • NRV required to be installed for byelaw compliance: Yes, on both hot & cold supplies |
|---|---|

Product markings and indicators:

- Branding position: 'Rangemaster' Laser marked body front (centered)
- Hot / Cold indication: H & C Lasered In Sans Serif Font On Handle Sides

Packaged properties:

Box length: 435 mm	Box depth: 70 mm
Box width: 340 mm	Units per outer:
Box has 'pressure warning sticker' ?	
Packaging branding:	Brown Rangemaster with black print

Tap only weight: 1.54 kg
Boxed weight: 2.12 kg
Total card weight: grams
Total plastics weight: grams

- Approval certificate number:
- Expiry date:

Warranty Summary (Full details available on request):

- Materials and workmanship defects warranted for 5 years
- Valves and working parts warranted for 5 years
- Surface warranty defects warranted for 5 year
- O-rings, hoses & gaskets warranted for 5 years

Care instructions:

- Clean the mixers and showers regularly as required, using soap, do not use any other cleaners.
- Regular cleaning will prevent the build up of lime scale and dirt
- After cleaning rinse thoroughly with clean water to remove any cleaner residue
- Residues of sink & worktop cleaners can also cause damage, so rinse with clean water after using, avoid contact with any abrasives